

DURACELL[®] PLUS[™]

Alkaline-Manganese Dioxide Battery

MN1400
Size: C (LR14)

Zn/MnO₂

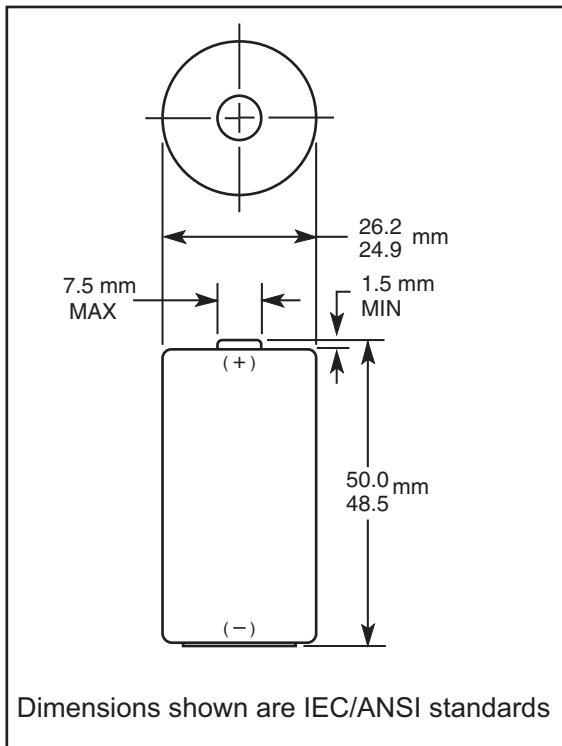

Nominal Voltage:	1.5 V
Nominal Internal Impedance:	150 m-ohm @ 1kHz
Average Weight:	69 gm (2.43 oz.)
Volume:	26.9 cm ³ (1.64 in. ³)
Terminals:	Flat
Operating Temperature Range:	-20°C to 54°C (-4°F to 130°F)
NEDA/ANSI:	14A
IEC:	LR14

TYPICAL DISCHARGE CHARACTERISTICS AT 21 °C (70°F)

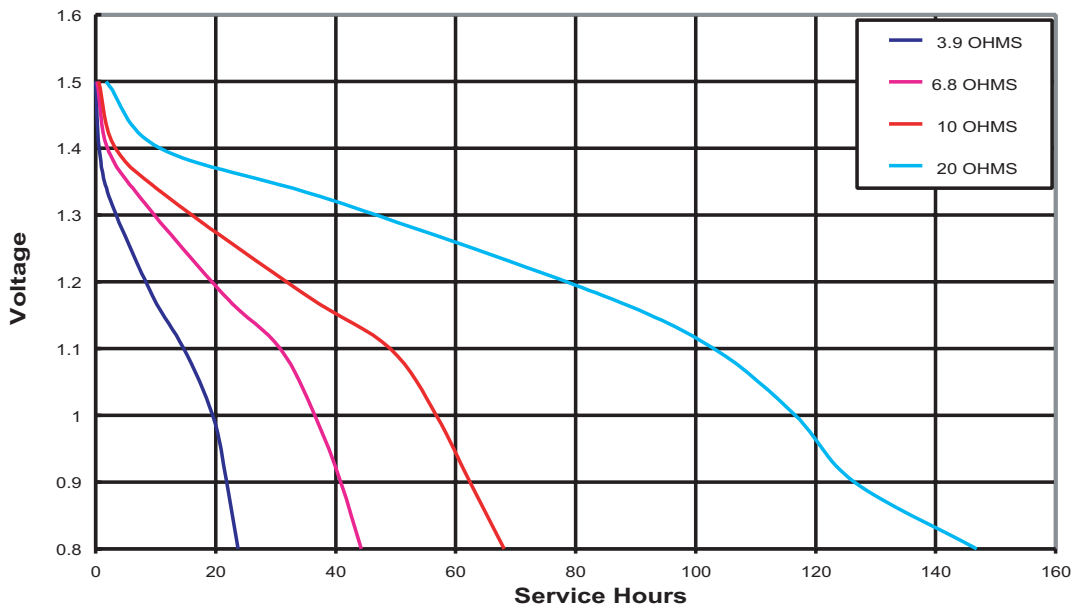

* Delivered capacity is dependent on the applied load, operating temperature and cut-off voltage. Please refer to the charts and discharge data shown for examples of the energy / service life that the battery will provide for various load conditions.

DURACELL[®] PLUS[™]

Alkaline-Manganese Dioxide Battery

MN1400
Size: C (LR14)

Zn/MnO₂

TYPICAL CONSTANT CURRENT DISCHARGE CHARACTERISTICS AT 21°C (70°F)

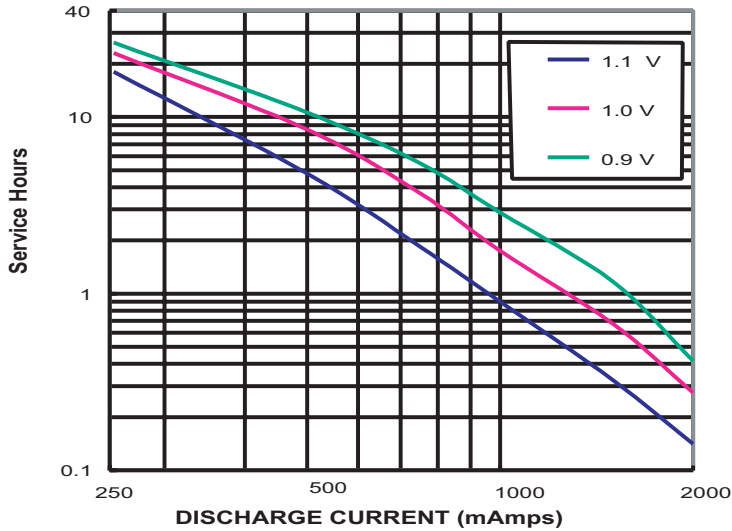

TYPICAL DISCHARGE CHARACTERISTICS AT 21°C (70°F)

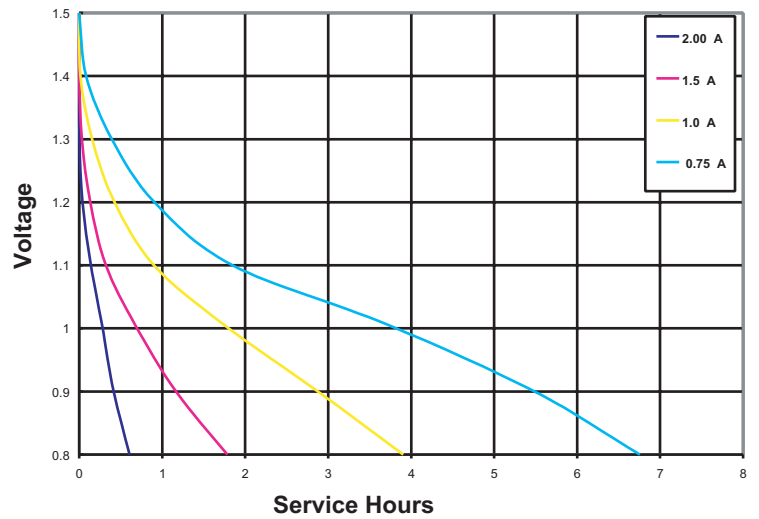

TYPICAL DISCHARGE CHARACTERISTICS AT 21°C (70°F)

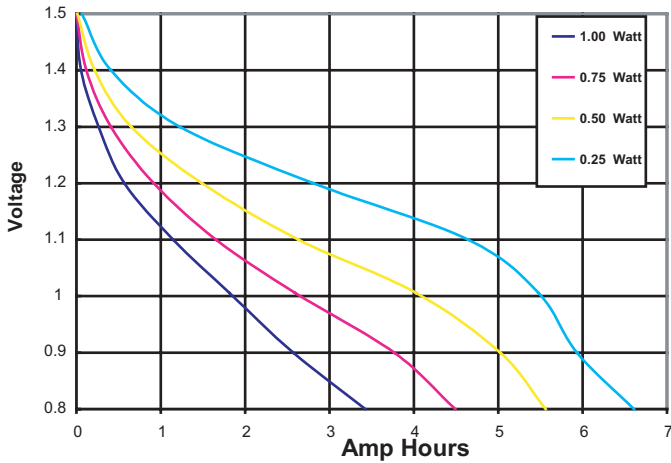

DURACELL[®]

BATTERIES

Berkshire Corporate Park
Bethel, CT 06801 U.S.A.
Telephone: Toll-free 1-800-544-5454
Internet: www.duracell.com

* Delivered capacity is dependent on the applied load, operating temperature and cut-off voltage. Please refer to the charts and discharge data shown for examples of the energy / service life that the battery will provide for various load conditions.