

Valeo

beep&park

PARKING ASSISTANCE System

Système d'AIDE AU STATIONNEMENT

Sensore di PARCHEGGIO

Sistema de AYUDA PARA ESTACIONAMIENTO

Sistema de AUXÍLIO DE ESTACIONAMENTO

EINPARKHILFE-System

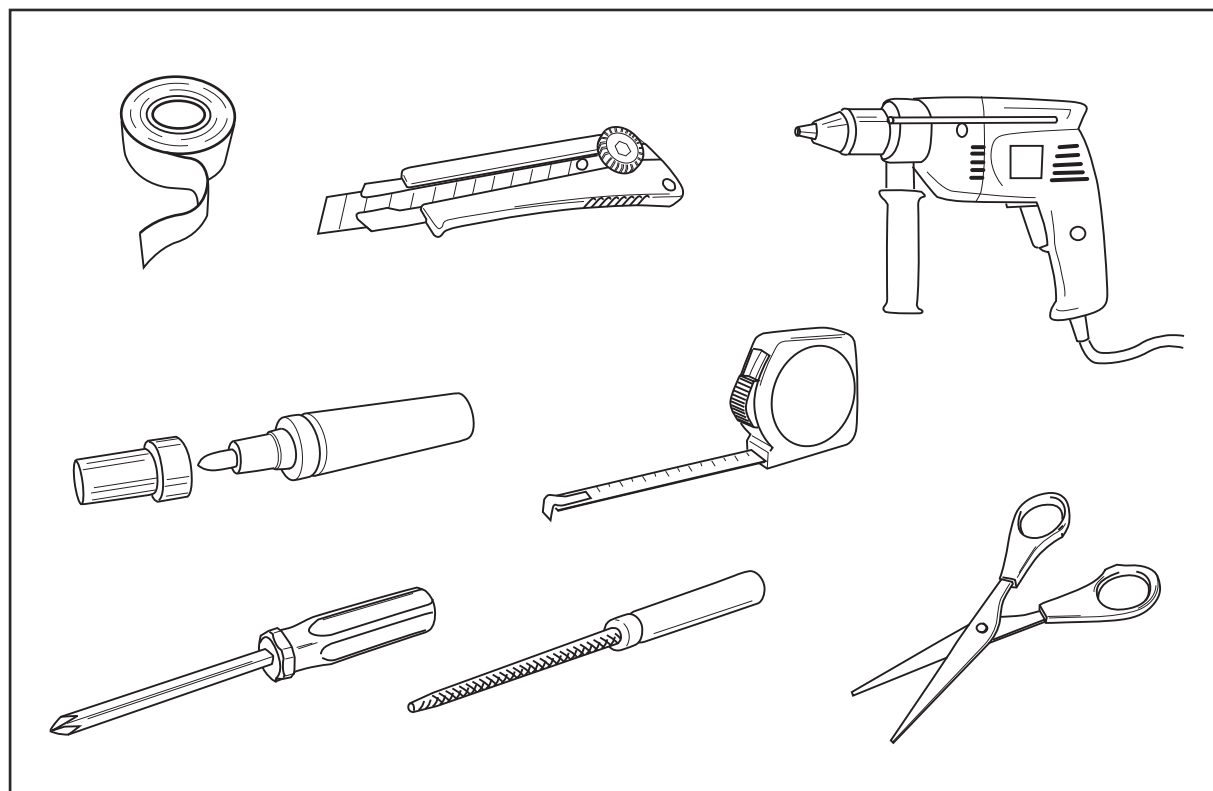
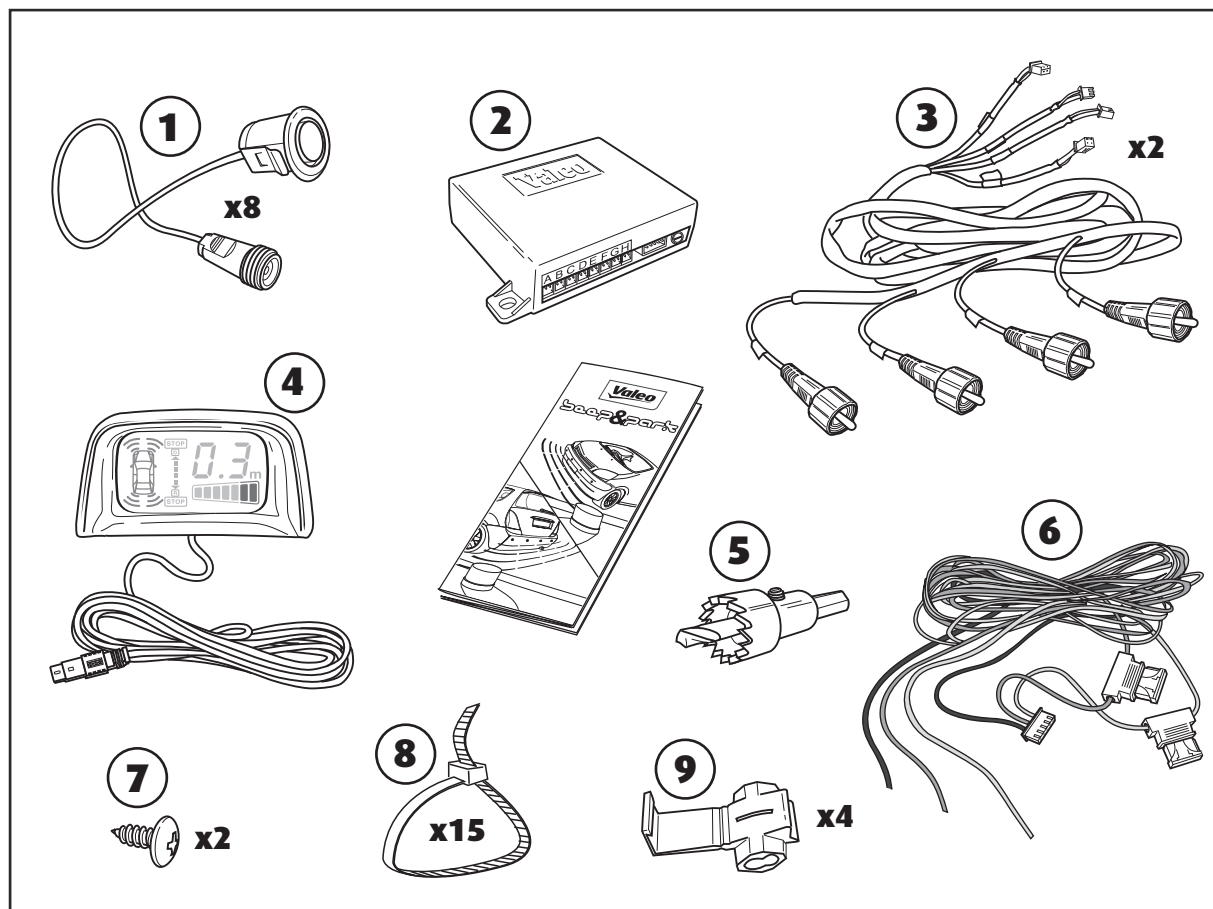

- Should be fitted by a professional.
- Nous vous recommandons de faire installer ce kit par un professionnel.
- Per il montaggio è preferibile rivolgersi a un professionista.

- Debe ser instalado por un profesional.
- Deve ser montado por um profissional.
- Einbau nur durch eine Fachwerkstatt.

632004



OK



OK

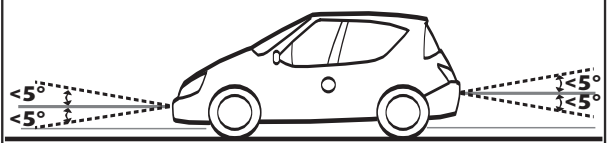

~~**OK**~~

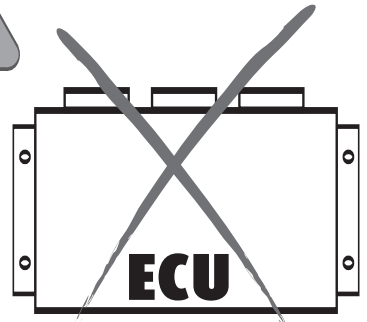
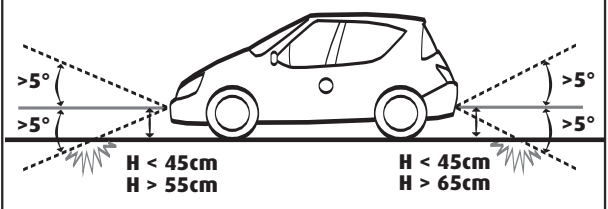

No Reset Necessary
Réinitialisation non nécessaire

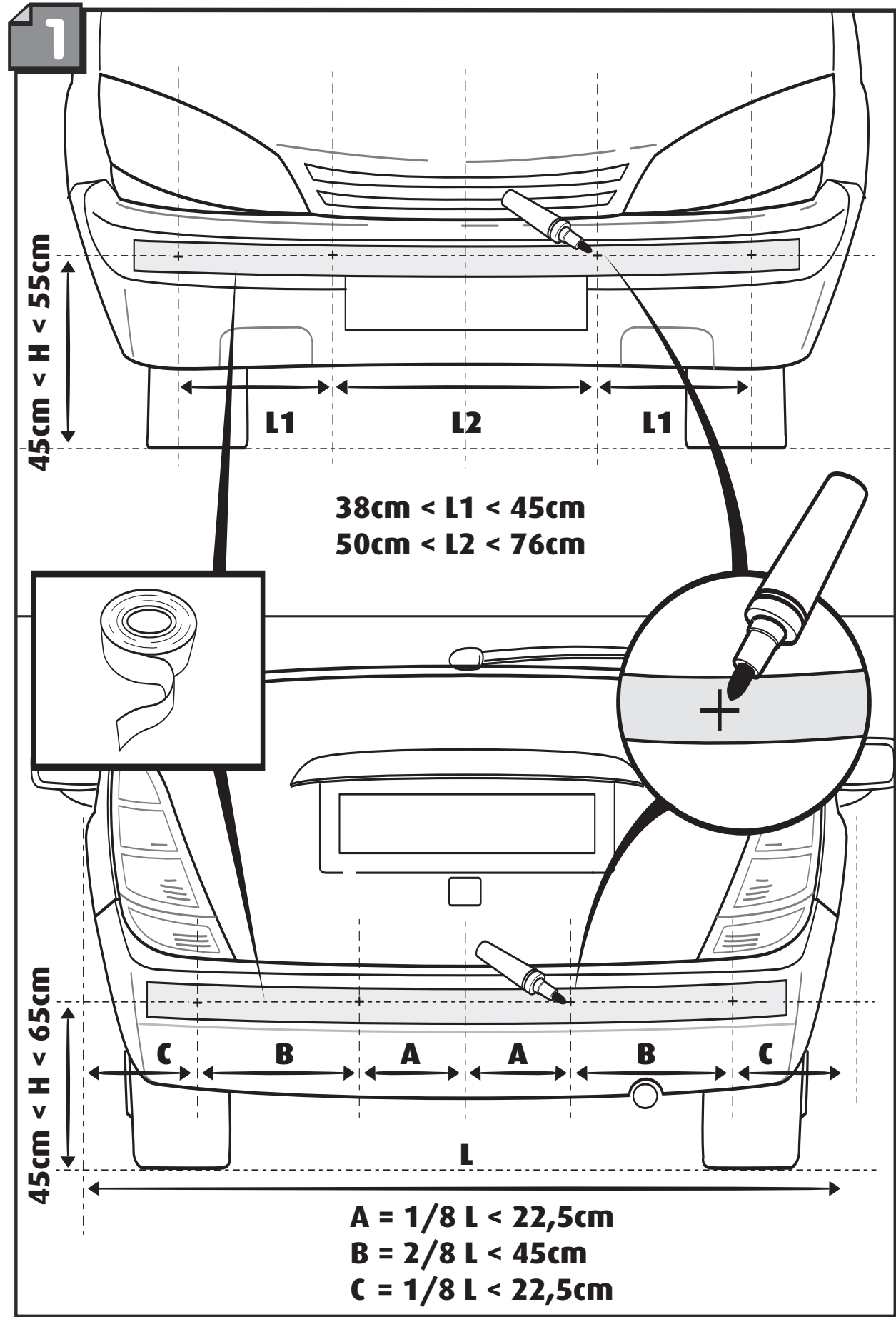

2

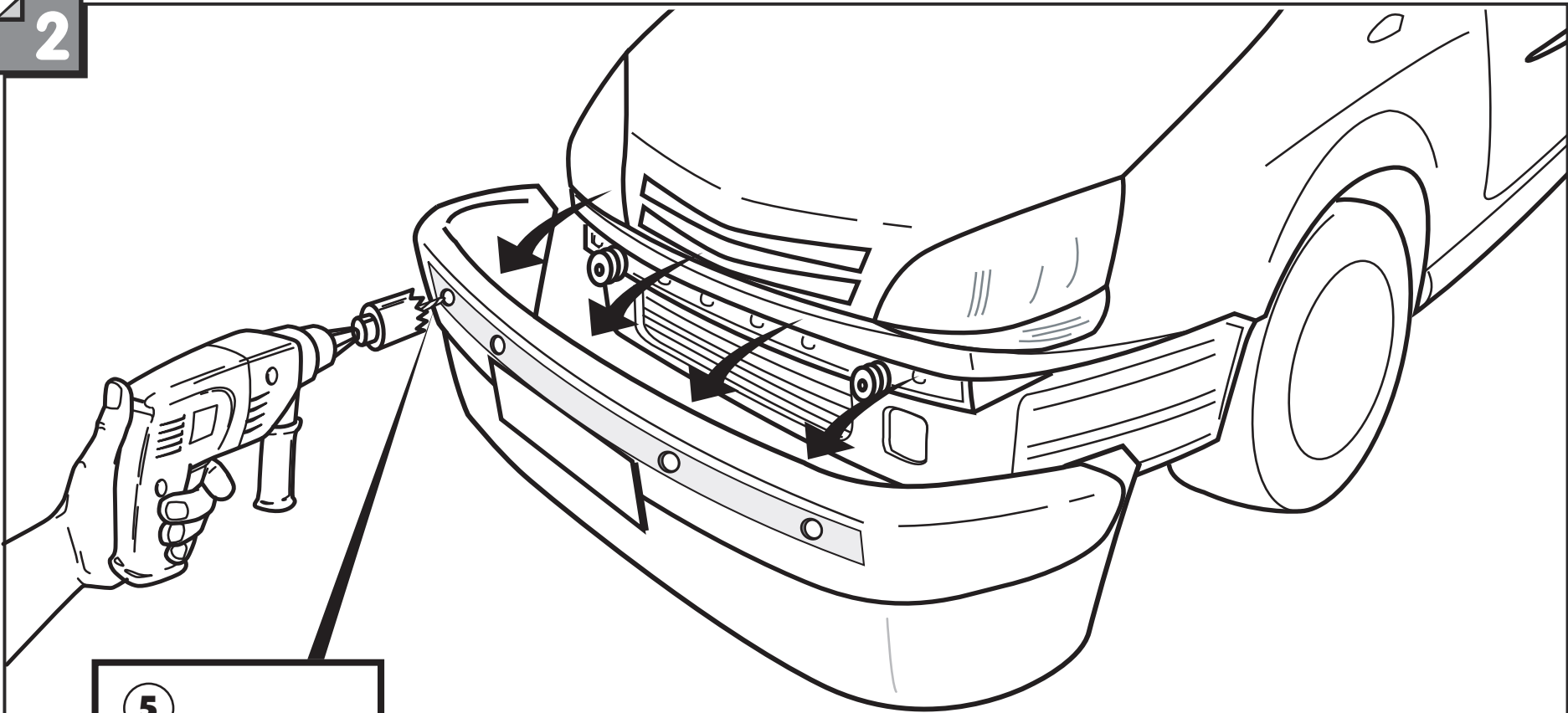

5

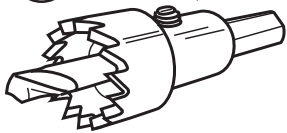

Ø = 18,5mm

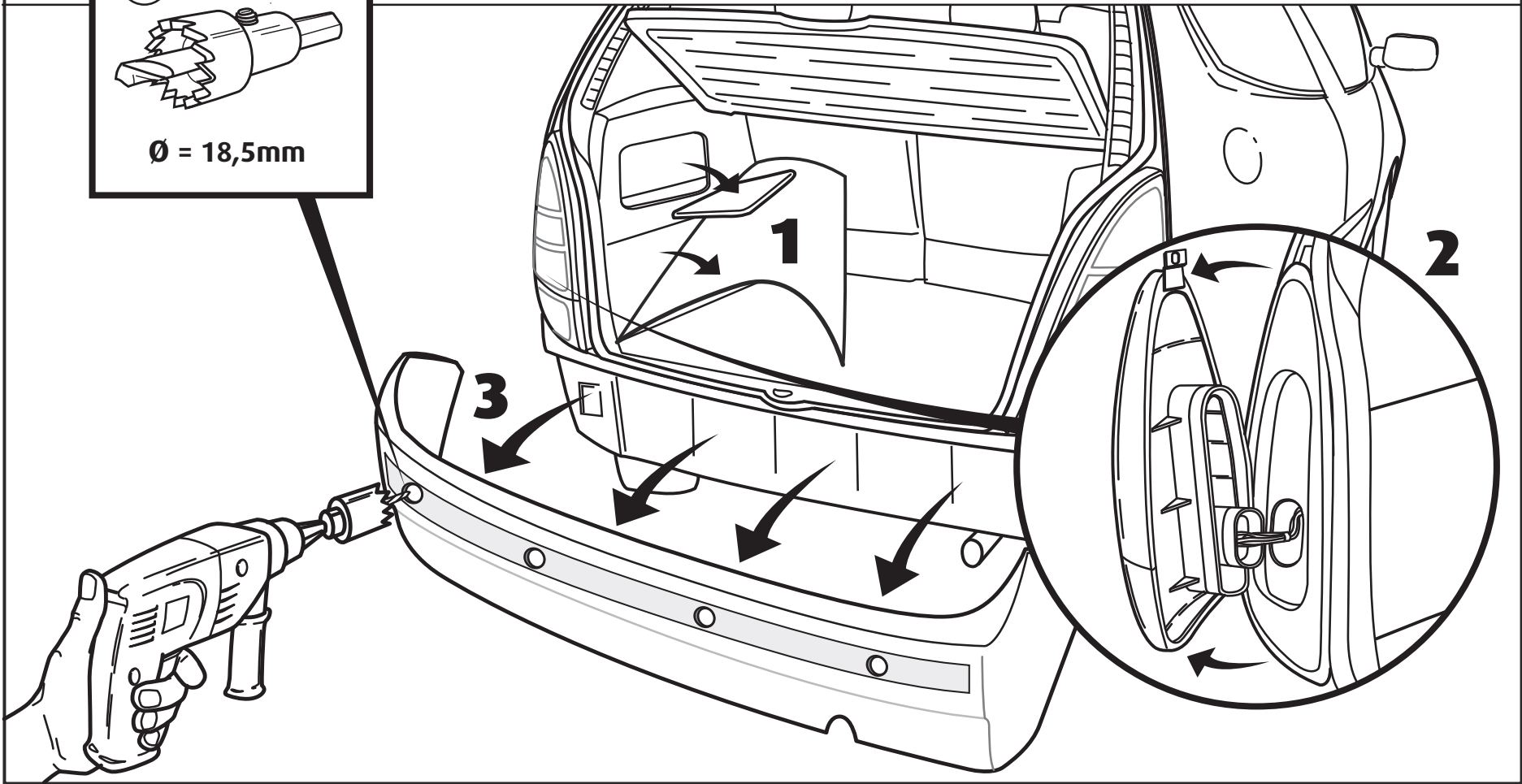

1

3

2

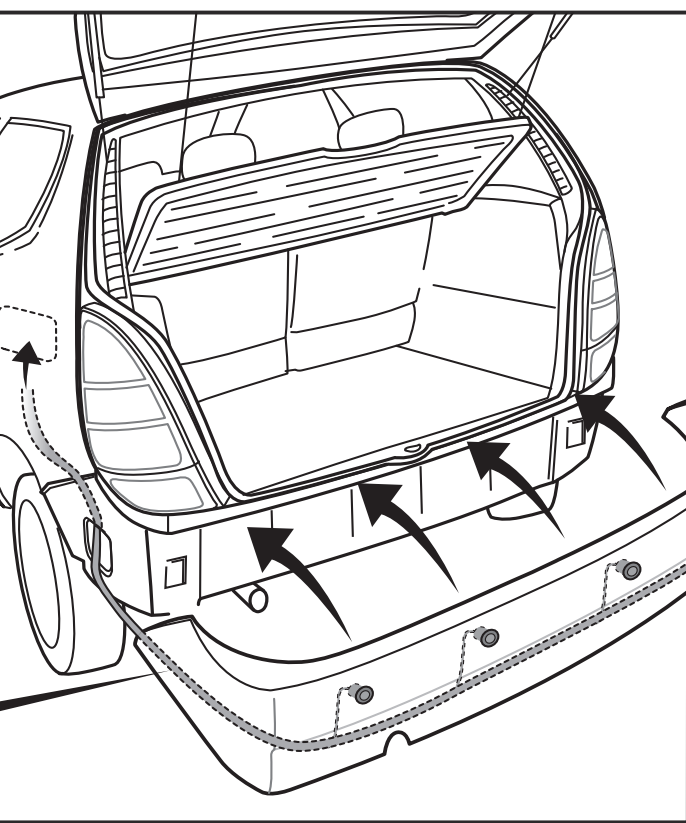
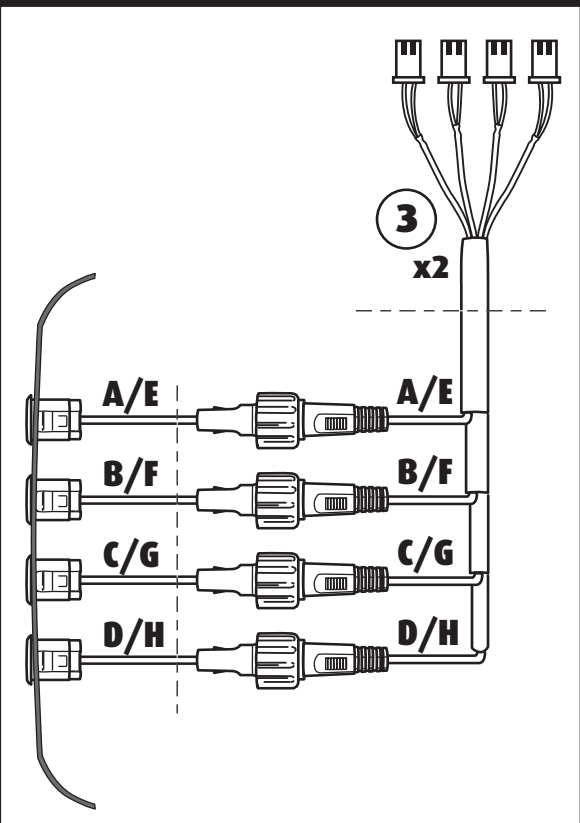
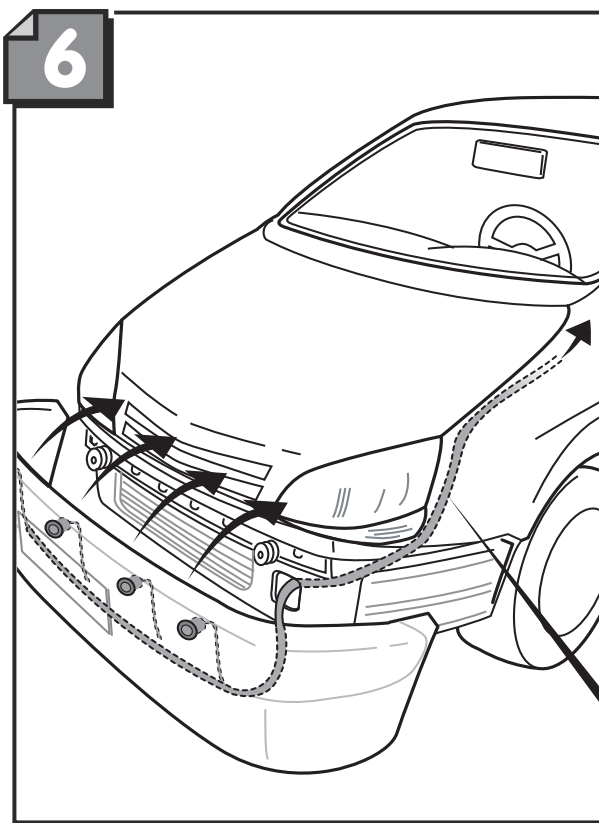
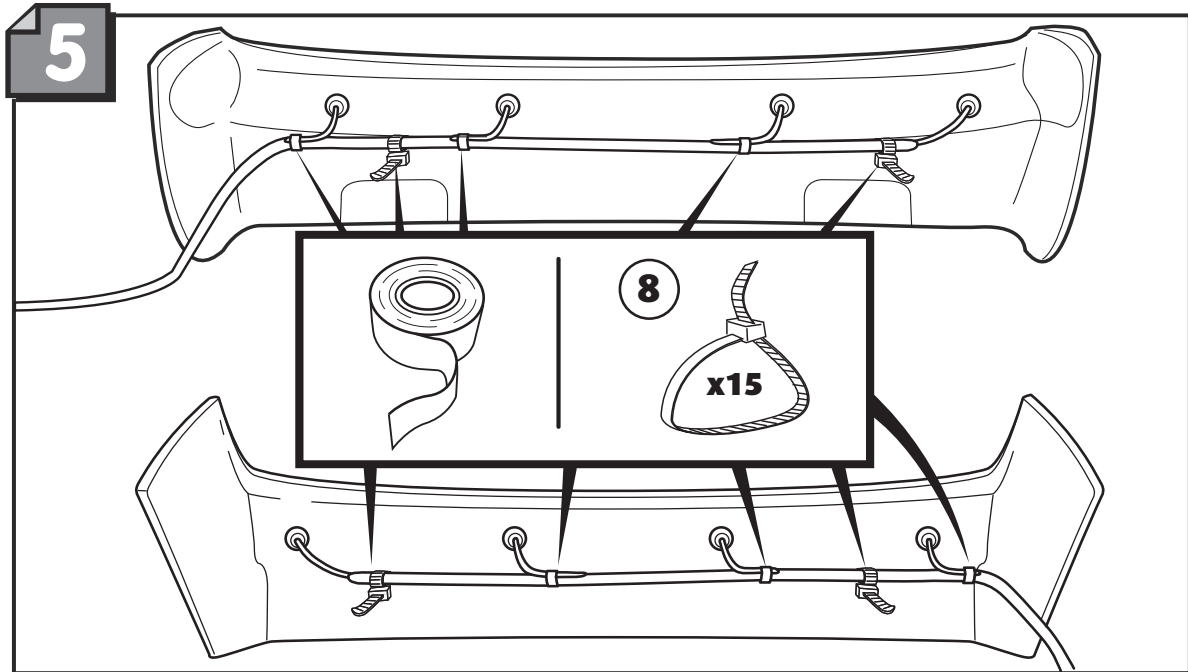
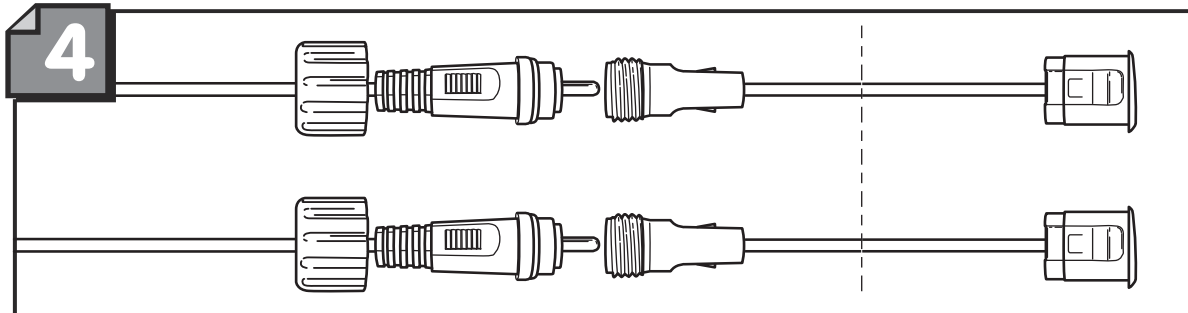
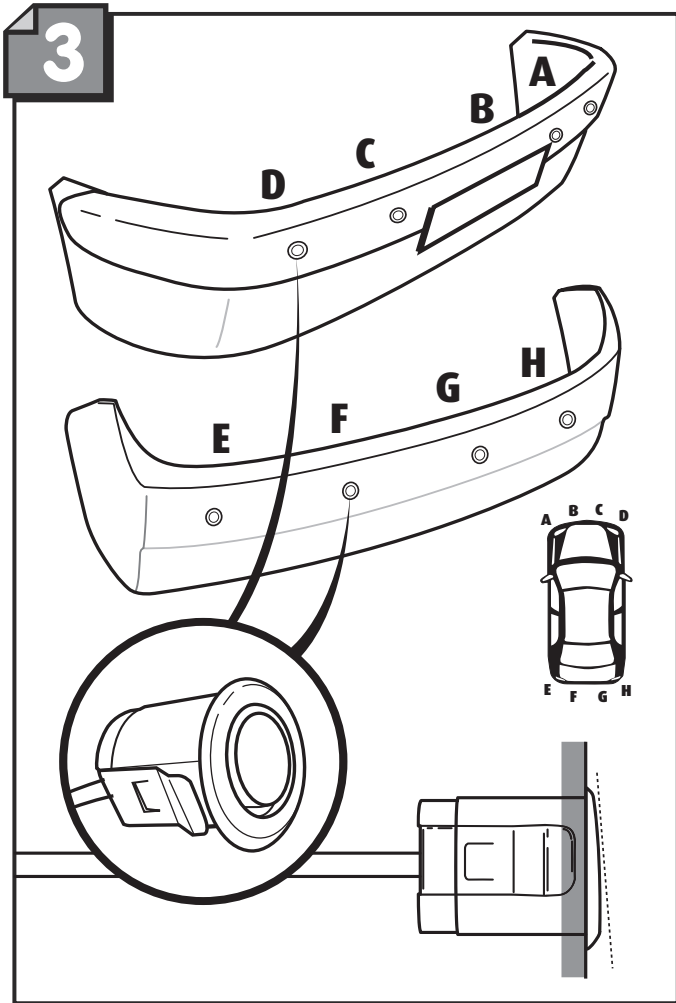

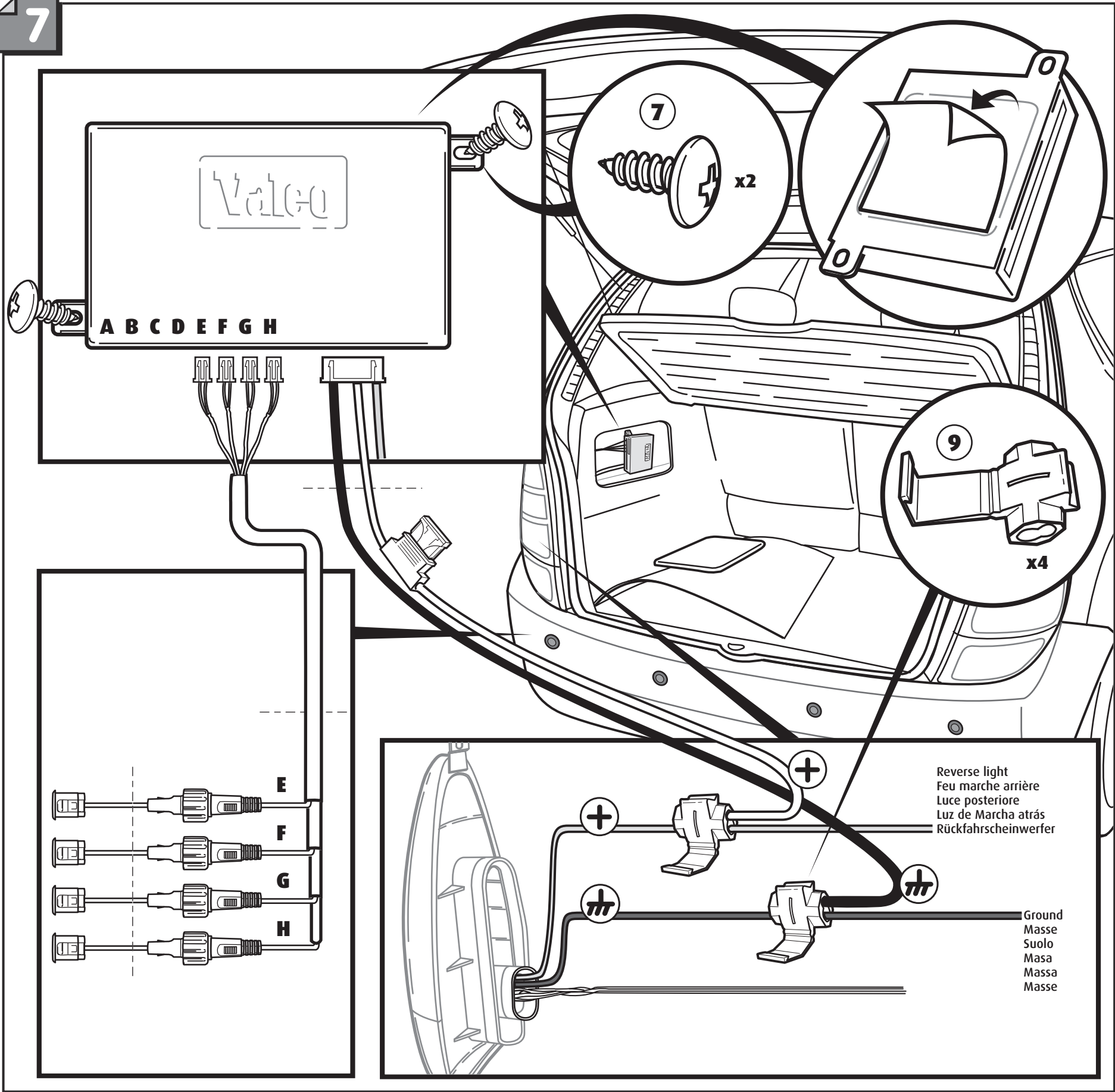

8

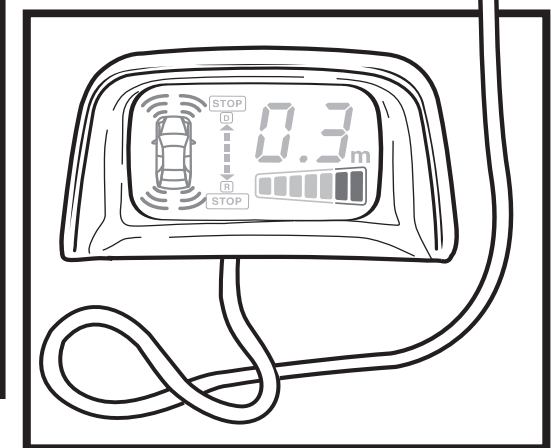
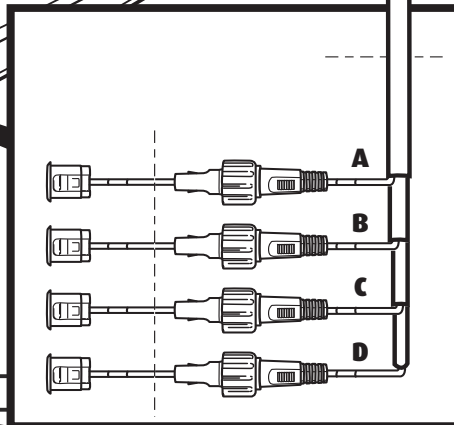
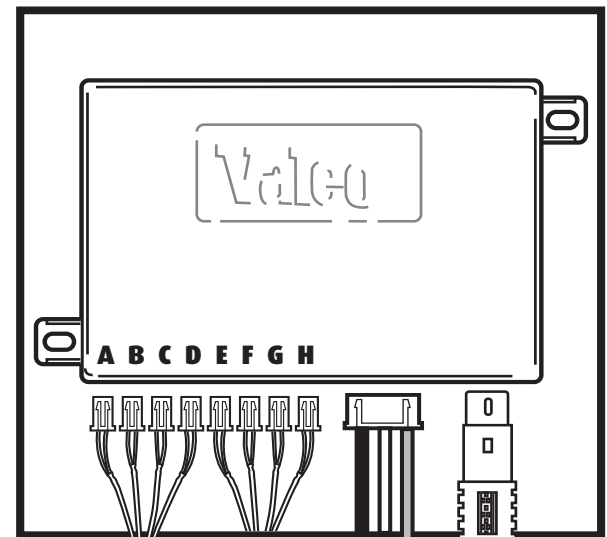
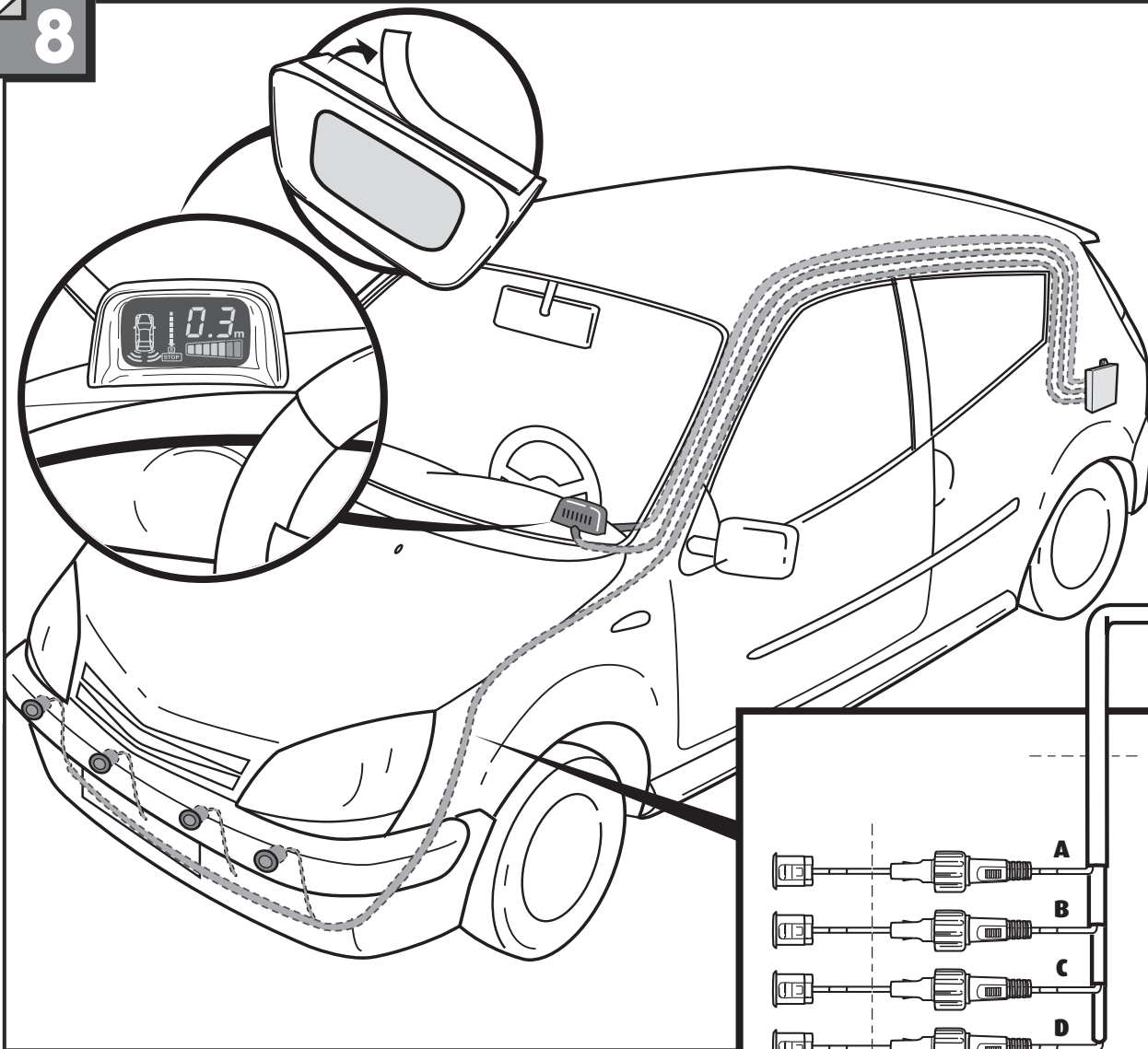

9

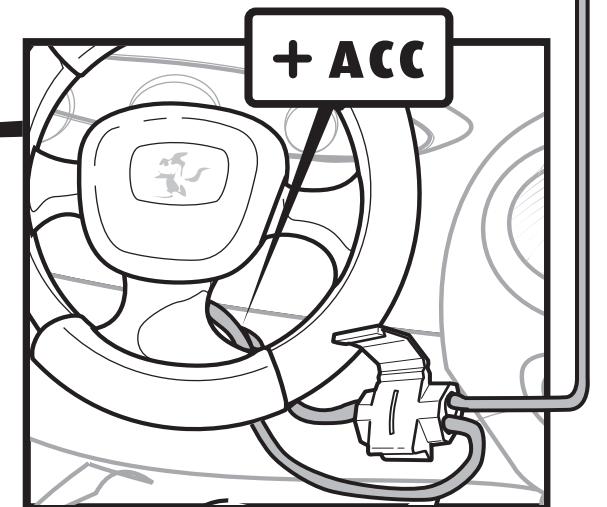
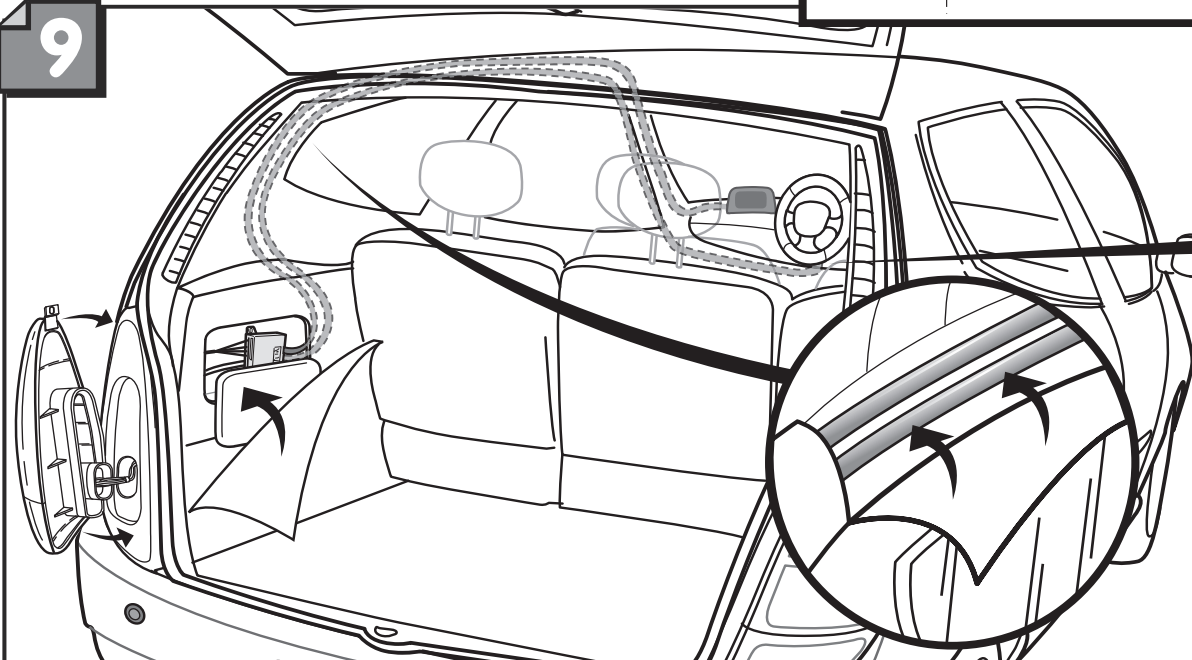

► If the tow bar is detected in the initial test, please proceed with the following initialisation step.

► Si votre système d'attelage est détecté lors de la mise en marche du produit, procédez à la phase d'initialisation suivante.

► Se il gancio traino è rilevato nella fase iniziale, procedete con la seguente fase di inializzazzione.

► Si el enganche del remolque es detectado en el momento de la primera puesta en marcha del producto, proceda a la fase de inicialización siguiente.

► Se o gancho do reboque é detectado no momento em que é colocado pela primeira vez o produto, proceda à fase de inicialização seguinte.

► Wurde Ihre Anhängervorrichtung bei der ersten Inbetriebnahme der Einparkhilfe erkannt, können Sie mit dem nächsten Schritt der Initialisierung fortfahren.

► **Important note:** After the 1st reverse gear, the tow bar must be detected ("beep, beep, beep"). The last 4 reverse gears can then be engaged successively.

► **Note importante :** Lors de la 1ère marche arrière, le système d'attelage doit être détecté ("beep, beep, beep"). Les 4 autres marches arrière peuvent ensuite être enclenchées de manière successive.

► **Importante:** Dopo la prima retromarcia, il gancio traino viene rilevato ("beep, beep, beep"). Dopo, inserire per 4 volte la retromarcia.

► **Nota importante:** Después de la primera marcha atrás, el enganche para remolque debe ser detectado ("beep, beep, beep"). Las otras 4 marchas atrás se pueden poner sucesivamente.

► **Nota importante:** Após colocar a 1ª mudança, a bola de reboque deverá ser detectada, ("beep, beep, beep"). As últimas 4 mudanças poderão ser engrenadas com sucesso.

► **Wichtig:** Wenn der Rückwärtsgang zum ersten Mal eingelegt wird muss die Anhängervorrichtung erkannt werden ("beep, beep, beep"). Das 4 malige Einlegen des Rückwärtsgangs danach kann direkt hintereinander erfolgen.

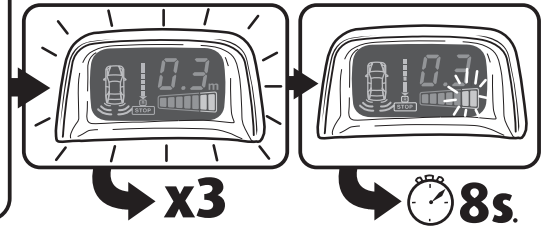
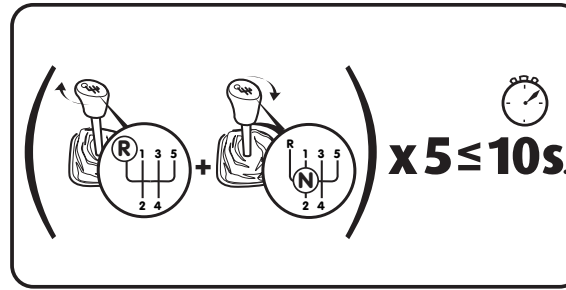

Harness / Faisceau électrique / Cavi di collegamento / Cableado / Cablagem / Kabel

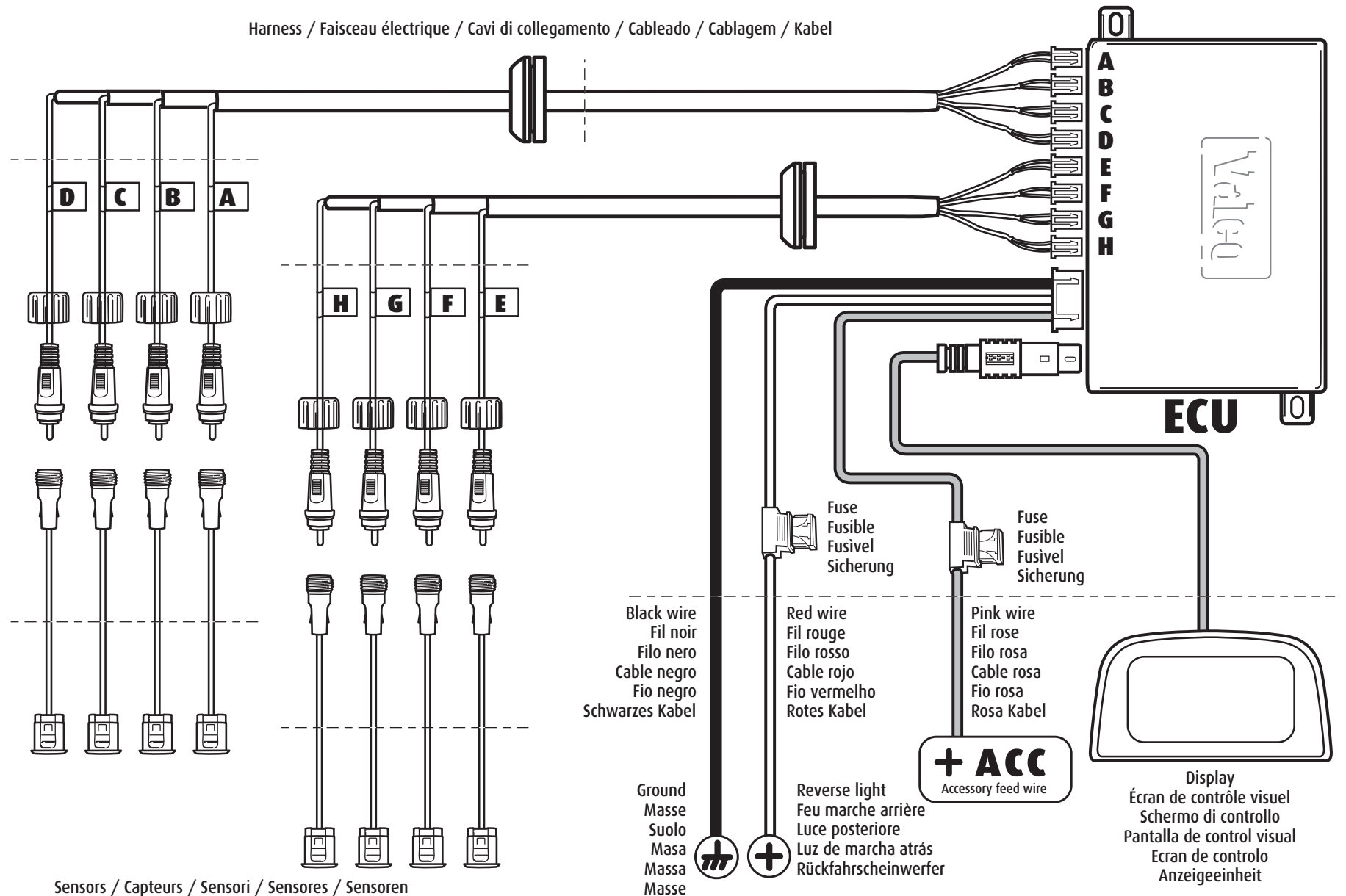

Symptom/Diagnosis • Symptôme/Diagnostic
 Sintomo/Diagnosi • Sintoma/Diagnosis
 Sintoma/Diagnóstico • Symptom/Diagnose



- ▶ If the buzzer makes a Beep Beep Beep noise without any obstacles, then it means that one or several sensors have been improperly fitted or damaged.
- ▶ E1 means one sensor is not working properly, E2 : 2 sensors, E3 : 3 sensors, E4 : 4 sensors. Screen flashing allows defect sensor identification.
- ▶ Check sensors are properly fitted.
- ▶ In case of crash, you can replace the concerned sensor by one available in the Valeo spare parts offer.



- ▶ Si, en l'absence d'obstacle, le buzzer émet un son Beep Beep Beep, cela signifie qu'un ou plusieurs capteurs ont été mal connectés ou endommagés.
- ▶ E1 signifie qu'un capteur ne fonctionne pas normalement, E2 : 2 capteurs, E3 : 3 capteurs, E4 : 4 capteurs. Le clignotement de l'écran permet d'identifier le capteur concerné.
- ▶ Vérifiez que les capteurs sont correctement montés.
- ▶ En cas de choc, remplacez le capteur défectueux par un capteur disponible dans l'offre Valeo en pièces détachées.



- ▶ Se il segnalatore acustico emette Beep Beep Beep senza alcun ostacolo in prossimità del veicolo, significa che uno o più sensori non sono stati montati correttamente oppure sono danneggiati.
- ▶ E1 significa che un sensore non sta funzionando correttamente, E2 : 2 sensori, E3 : 3 sensori, E4 : 4 sensori. Se il display lampeggia è stato individuato un difetto del sensore.
- ▶ Verificare che i sensori siano stati montati correttamente.
- ▶ In caso di urto, è possibile sostituire il sensore danneggiato con uno disponibile nella gamma parti sciolte Valeo.



- ▶ Si el zumbador produce un Beep, Beep, Beep sin ningún obstáculo, esto significa que uno o varios sensores han sido incorrectamente montados o dañados.
- ▶ E1 significa que un sensor no está funcionando adecuadamente, E2 : 2 sensores, E3 : 3 sensores, E4 : 4 sensores. La pantalla permite identificar el sensor defectuoso.
- ▶ Verificar el correcto montaje de los sensores.
- ▶ En caso de golpe, es posible sustituir el sensor afectado por otro disponible en la oferta de despiece Valeo.



- ▶ Se o som faz um barulho Beep Beep Beep sem obstáculos, isso significa que um ou vários sensores foram mal montados ou danificados.
- ▶ E1 significa que um sensor não está a funcionar bem. E2 : 2 sensores, E3 : 3 sensores, E4 : 4 sensores. Ecran flashing permite detectar sensor defeituoso.
- ▶ Verifique se os sensores estão bem montados.
- ▶ Em caso de acidente, pode substituir o sensor danificado por um disponível em Peças de Reparação Valeo.



- ▶ Wenn das Gerät ohne in der Nähe eines Hindernisses zu sein 3 Biep-Töne erzeugt, weist dies auf einen oder mehrere falsch angeschlossene oder defekte Sensoren hin.
- ▶ Die Anzeige "E1" bedeutet, dass ein Sensor nicht richtig arbeitet., "E2" = 2 Sensoren arbeiten nicht richtig etc...
- Anhand des blinkenden Bildschirms kann festgestellt werden, welcher Sensor defekt ist.
- ▶ Kontrollieren Sie bitte, ob die Sensoren richtig montiert und angeschlossen sind.
- ▶ Ein defekter Sensor kann durch einen Sensor aus dem Valeo Ersatzteile-Programm ersetzt werden.

Beep...Beep...Beep...

